



YD-315 Rotary Microtome

Operation Manual



Important information

All information, data, comment and prompt in this manual is contained in normal scientific knowledge and common craftwork technology.

Please read this manual book carefully before operating the Microtome. Especially pay more attention to Chapter Three of Safety direction and Warnings in other chapters.

Only eligible operators can manipulate the instrument according to the direction of this manual. This instrument is just for tissue section of histology and pathology.

Only professional and eligible maintenance staff can maintain the microtome.

Protect and Maintain will be supplied by our After-sale service department.

Because of the up-to-date technical continuous, we have the right to make improvement of technical specifications without notification.

Nameplate on back of instrument indicated The information of model, identification number and manufacture date.

Definition

“Warning” ---- if violate operation sequence, there will be a serious accident and it will hurt the operator or instrument severely.

“Attention” --- if violate operation sequence, maybe cause a error of operation and not work continually, even damage the instrument possible.

Index	
1.General description.....	3
2.Main technical parameters.....	4
3.Instruction of safe operation.....	5
3.1 Installation of handwheel	5
3.2 Safe syetem of blade holder.....	6
4 Illustration of microtome.....	7
5.Unpacking and Installation.....	8
5.1.Installation of microtome.....	8
5.2.Requirement of placement.....	8
5.3.Installation of waste tray.....	9
6.Orienting System of Specimen.....	9
6.1Collet of embedding basket	10
6.2 Exchange between collet of embedding basket and paraffin block... 10	
6.3.Installation of tissue specimen.....	11
7.Fixed system of blade holder.....	12
7.1.Installation of blade holder.....	12
7.2.Installation of disposable blade.....	12
7.3.Adjust section angle.....	13
7.4.Sway blade holder.....	13
7.5.Safety Precautions of blade holder operating.....	14
8.Operating of slice.....	14
8.1.Selecting of slice thickness.....	14
8.2.Fast marching handwheel.....	15
8.3.Trimming.....	15
8.4.Section.....	16
8.5Precautions of paraffin section.....	16
8.6 Adjustment of specimen.....	18
8.7.finish work.....	18
9.Problems and Solution.....	19
10.Cleaning and maintenance.....	20
10.1.Disassembly of blade holder.....	20
10.2.Cleaning.....	21
11.Store and Transportation.....	22
12.Packing list.....	22
13.After-service and Maintenance	23

1.Outline:

Thank you for your choice of YD-315 Computerized Microtome.

YD-315 Rotary Microtome is used widely for routine and laboratory slice test in medical colleges, Animal and Plant Inspection and Quarantine organization, Scientific research organization. It is used for slicing different level of thickness tissue specimen section for pathological diagnosis..

YD-315 rotary microtome is latest products which be designed to adapt to the traditional operating habit of broad range of consumers. such microtome absorbs the distillate of microtome technology of our company with history more than 10 years, combining with Structure character of mainstream microtome in domestic market, adoptting the advanced import roller guide shoe from Switzerland(SCHNEEBERGER), nimble feeding system without gap,and exempt lubrication, guarantee the high precision, increase of service life

YD-315 Rotary Microtome with novel structure 、 advanced features 、 excellent performance.

Precise and reliable Microfeed Mechanism with alam system for stroke limit

The handwheel in the right can be locked in any position,and locked in highest position,provide the maximal security and convenient.

The handwheel in the lift can lead the specimen advance and retreat fastly and conveniently

preparation forceps can be adjusted up/down left/right,trimming all kinds shape of tissue specimen easily.

New type of blade holder can be moveing around and location easily, improving the work efficiency and Economic effects obviously by utilizing sharply cutting edge of the diaposable blade

The section waste can be collected by wide tray at bottom , it's more environment-friendly

Blend into new design of ergonomics concept ,bing the indefatigability and confort effect to operator

2. technical parameter:

Environmental temperature +10°C — +40°C

Environmental moisture 35% — 80%

Section thickness range : 0.5 — 60 um

Slice thickness adjustment 0 — 2 um increment 0.5 um

2 — 10 um increment 1 um

10 — 20 um increment 2 um

20 — 60 um increment 5 um

Horizontal specimen stroke 25 mm

Vertical specimen stroke 59 mm

Specimen orientation

Horizontal 8°

Vertical 8°

Rotation ±90°

Movement range of blade holder

front and back ± 25mm

left and right ± 20mm

Dimension and weight

Length (460mm) ×width (276mm) ×high (278mm)

Height of cutting edge 105 mm

Net weight 29 kg

Gross weight 40 kg

3.Safety operating instruction:

The safety devices on the instrument and accessory must not be modified or removed

3.1 Safe device of handwheel: the spanner controls the handwheel, lock the handwheel at any position of rotation.

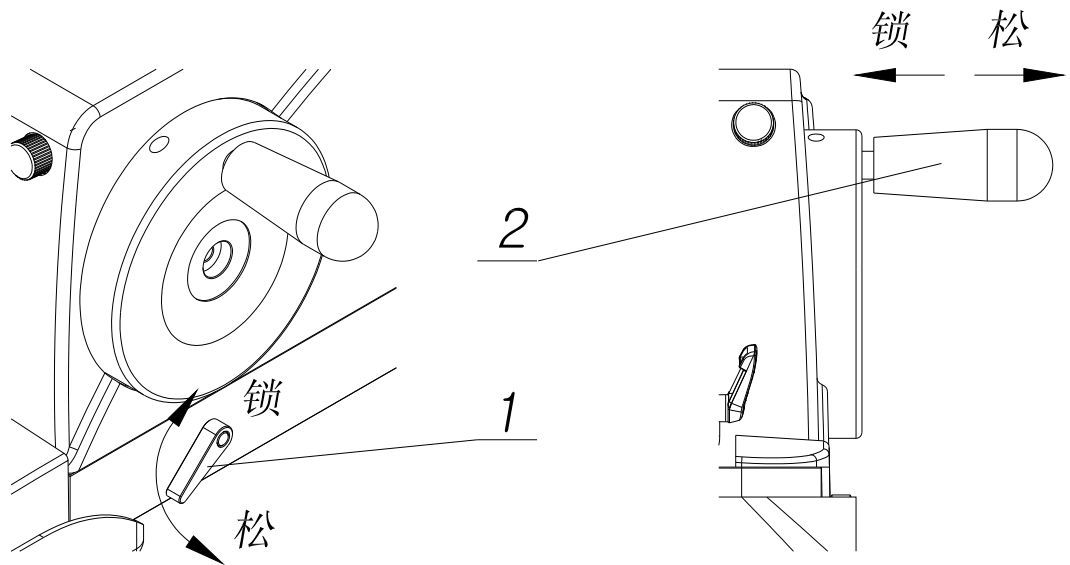

1、safty handwheel 2、rocking handle of handwheel

before adjusting the section and specimen must be lock the handwheel

The handwheel can be locked in any direction with the locking spanner . The locking spanner can be set on the locked or released position on the right side of the base. Also can push the rocking handle at the top position to open or release the locked

Lock: 1. convenient locking during manipulating——push the pry bar to the top, the handwheel can be locked at any position

2. safety lacked be used during the break——face the direction of the handle to push the hand wheel,shaking to the the acme,the lockpin slid into lock tube aumomatic, then the handwheel been locked

3.2 safety device of blade holder: finger protection system which can flip up and down

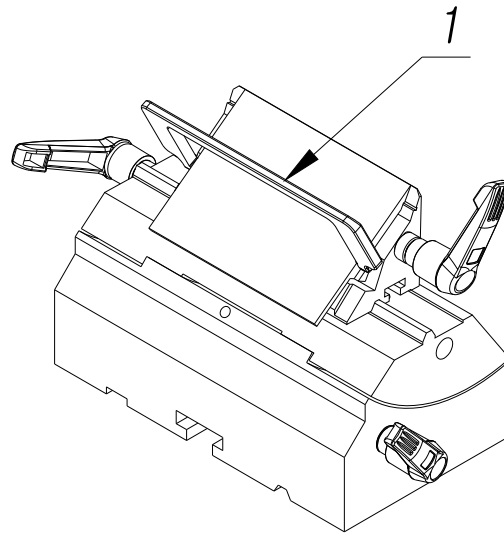

warn: operating or changing the specimen , knife and disposal blade , even during breaks, it must always cover the cutting edge with the knife guard

before operateing or changing the specimen or knife, and during breaks, it must always cover the cutting edge with the knife guard

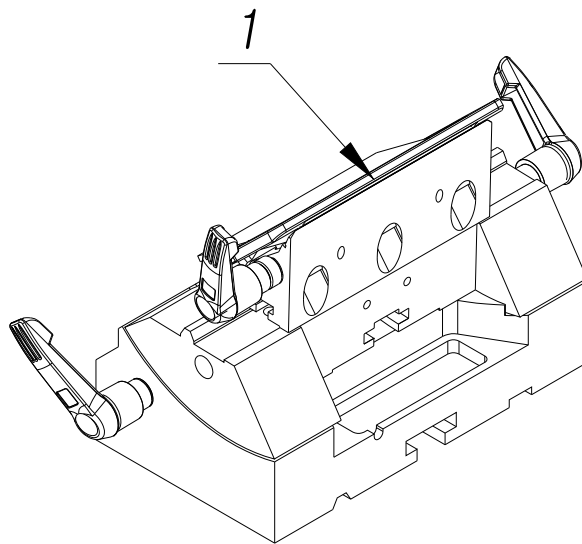

Every knife carrier has different shape knife guard (1) it can be used to cover the cutting edge completely.turn over the knife guard handle to cover the knife edge.

4.illustration

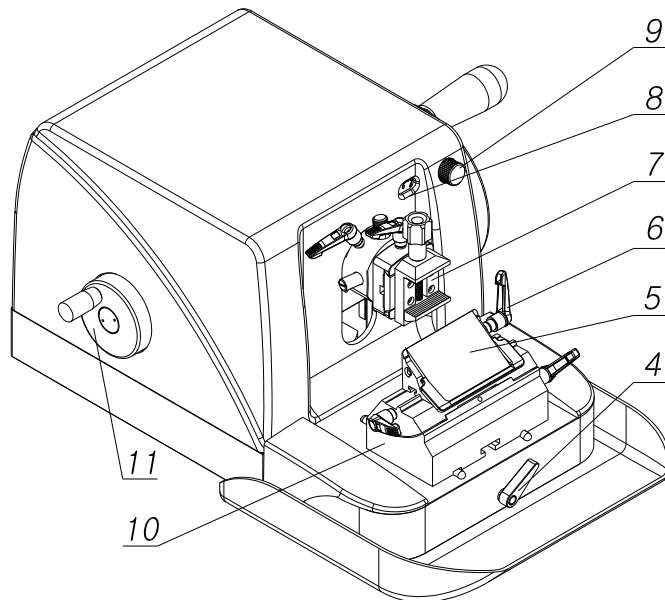
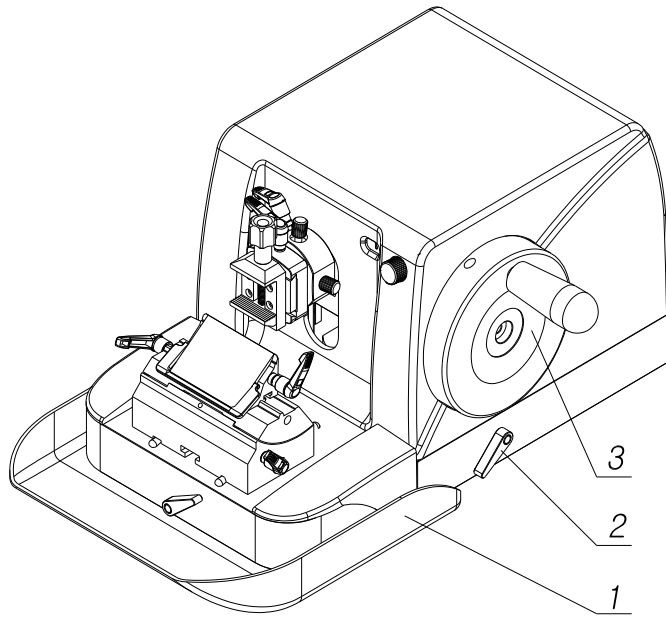

1. waste tray 2. the lock spanner of handwheel 3.handwheel 4. the lock spanner of blade holder 5. knife carrier 6. the lock spanner of blade 7. specimen clamp 8 scale indication 9.the adjust knob of scale 10.blade holder 11.speed handwheel

5.Unloading Machine and installation:

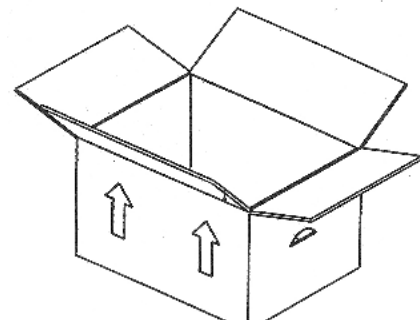

Please check the weather Tip-n-Tell indicators  on the outside of the carton box is upon .Cut off the plastic bands on the outside of carton. Take out the accessory box and the instruction manual. withdraw the foam around packing.

warn ! Do not put forth your strength to the encloser, blade holder or wax block clamp during moving the instrument , instand holding the bottom of the instrument

5.1Installing the microtome:

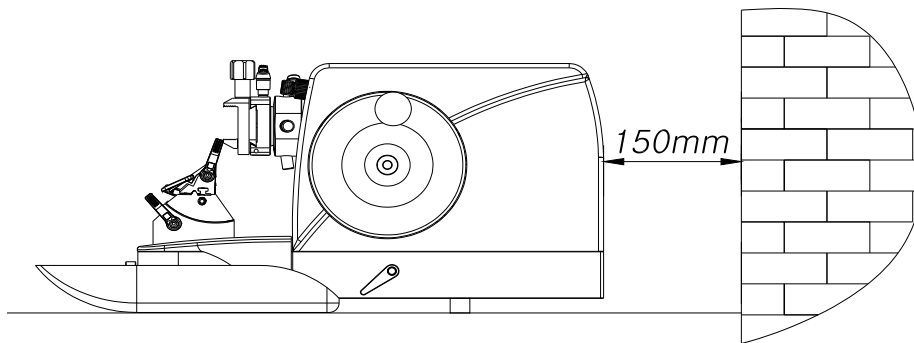

Place the microtome on a stable laboratory table, and back away from the wall about 150mm.

5.2 Requirement of placement

1. The position must meet the following requirements:
2. Stable, no vibration laboratory table
3. no vibration floor
4. room temperature always between $+5^{\circ}\text{C} \sim +40^{\circ}\text{C}$

5.3 Installing of waste tray:

Insert the waste tray as the illustrated indicates.

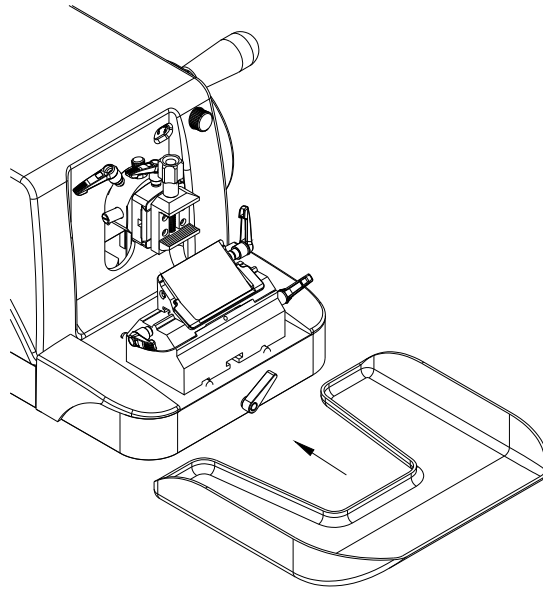

6. The specimen Orienting system

The specimen orienting system consists of specimen clamp and angle adjusting device. The specimen clamp can be adjusted right and left or up and down to obtain the ideal slicing angle.

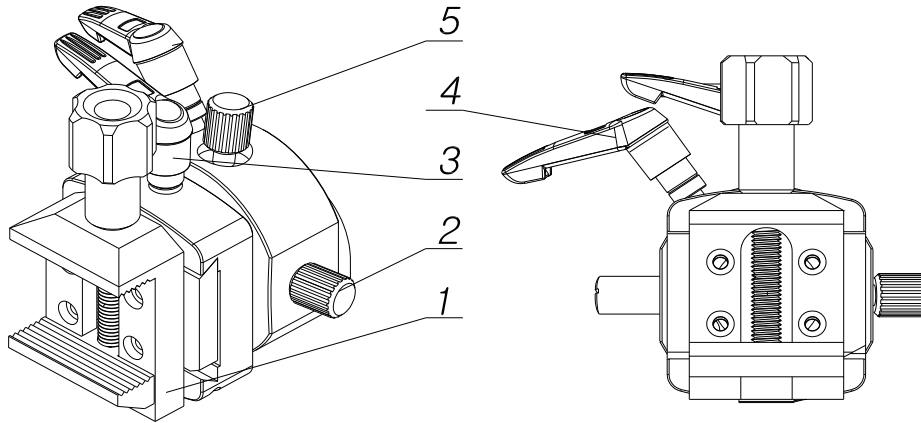

1. specimen clamp 2. screw for left and right 3. collet exchange handle 4. locking spanner of gear block 5. screw for up and down

Attention : The specimen clamping system has been installed and adjusted appropriately before leaving the factory. Users don't need to dismount and adjust by himself.

6.1 Steel struture holder

The instrument is furnished with a disposable embedding basket collet which is Unique design,it can rapid clamp the tissue specimen,improve the efficiency of work.it can be exchanged between embedding basket collet and wax block clamp,facing the requirment of different kinds of tissue specimen.

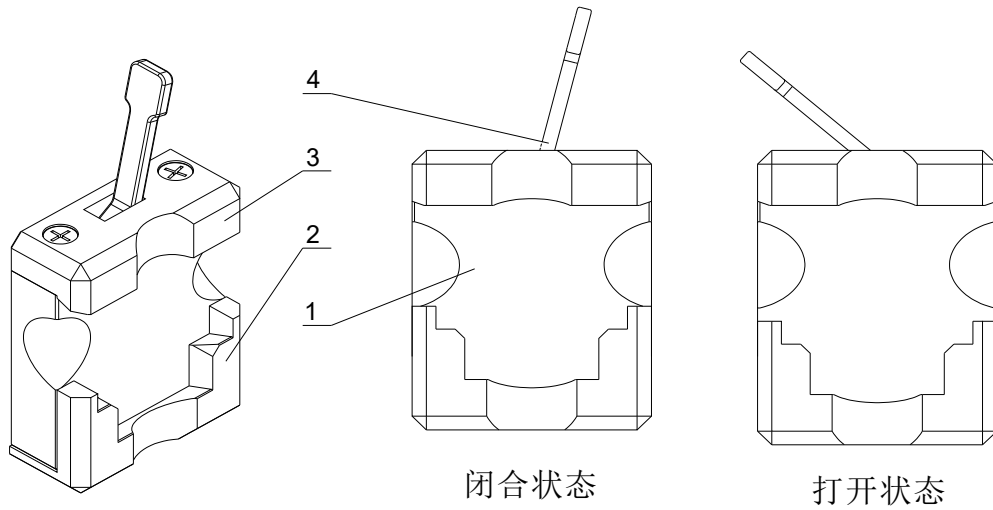

1. gear block 2 moving jaw 4 regular jaw 4 spanner control open and closed

6.2 Exchange between collet of embedding basket and paraffin block clamp

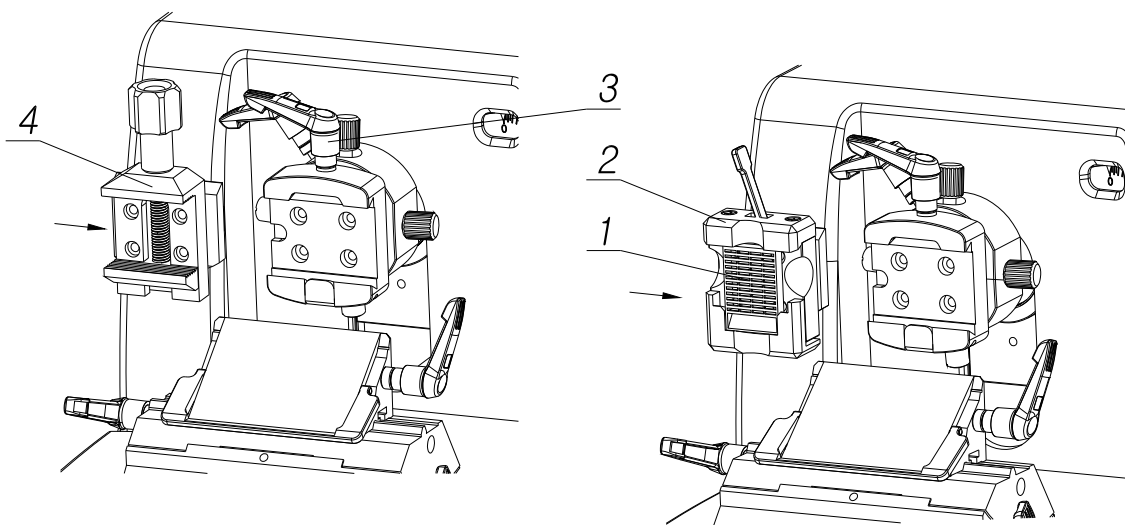

p1.plastic embedding basket 2 rapid embedding basket collet 3 handle of collet exchange 4 specimen clamp

When exchange different of clamp ,locked the handwheel,it is better to shift out the part of balde holder,then counterclockwise rotation and release handle of collet exchange, when the lock is loosened then you can extract the embedding basket collet or wax block clamp in the direction of the left.it can be reinstall in the reverse order after exchange,pay attention to insert wedge into the dovetail groove, then turn clamp and exchange spanner, just tightening the movable lock.

6.3 Installation of tissue specimen

1. releasing the knob of specimen clamp(3) to opening the mouth of tongs(2),putting in paraffin specimen and tightening it when using the ordinary paraffin to embedding tissue block

2.when using the disposable plastics embedding basket, release open and colsed spanner of embedding basket clamp(5),after putting in embedding basket(4) ,turn back the open and colsed spanner to restoration

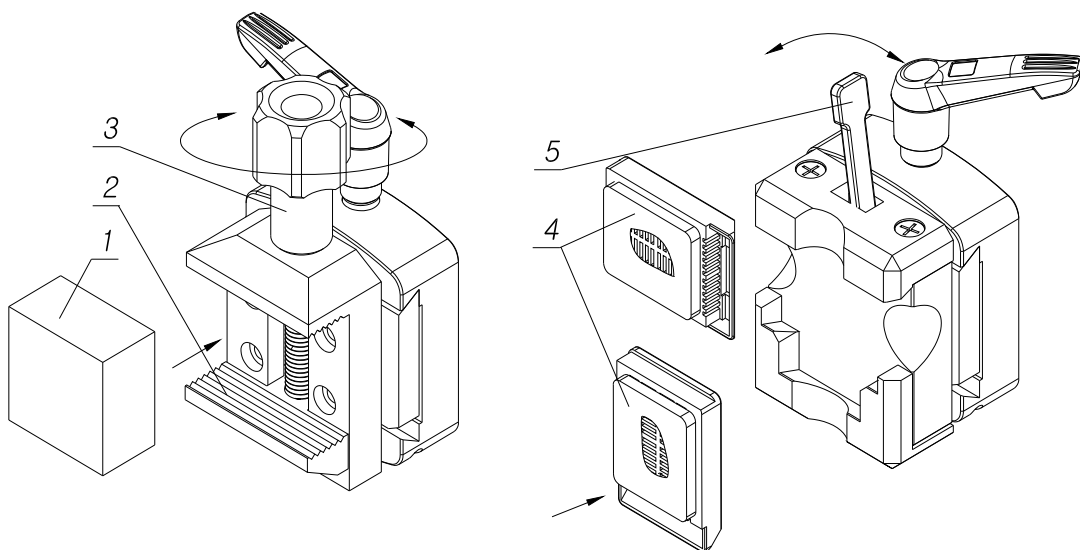

exchanging specimen clamp or loading tissue specimen , it must always lock the handwheel and cover the cutting edge with the knife care!

7.Fixed system of blade holder

7.1 Installment of the blade holder

1. pull out waste bath, release adjustment spanner of blade holder(1), push the dovetail groove of holder forward along with Rail that in the base of instrument, The locking block (2) of the blade holder enter the T shape groove(4) of the blade holder.

2.lock adjustment spanner(1), tighten the blade holder on the base of instrument,insert waste bath.

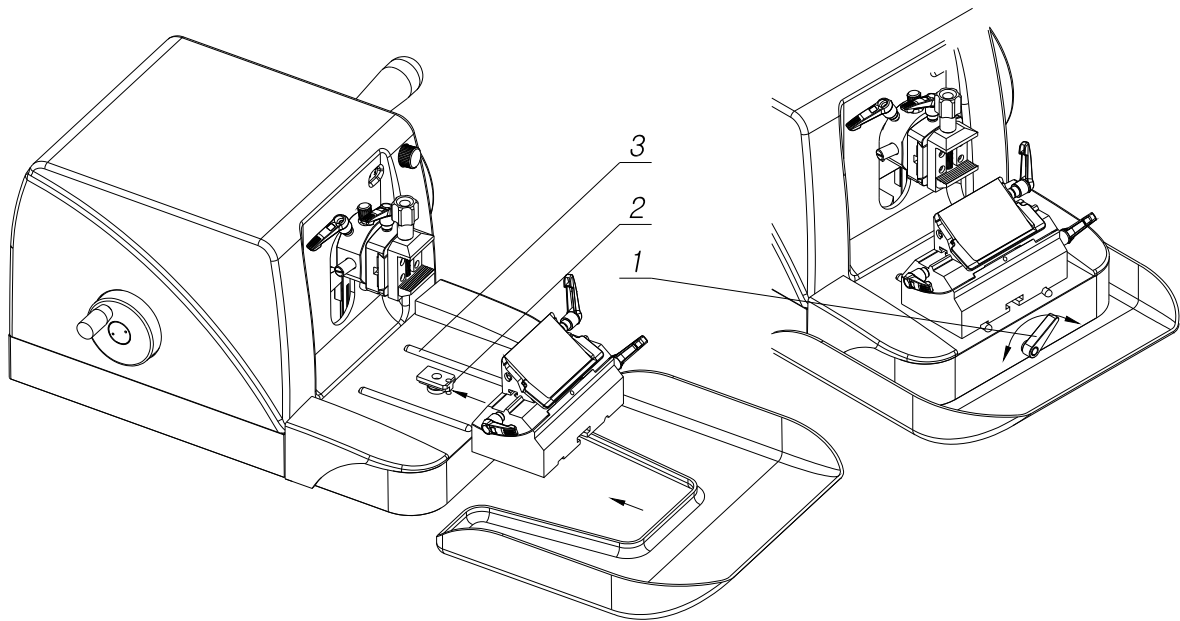

7.2 Installment of the disposable blade

1.turn down the knife care(2),release lock spanner of blade(1), At this ,point sickle clip will bounce automatically

2. tuck the disposable blade from the side of direction(3) and lock spanner(1),turn back knife care to the safety position.

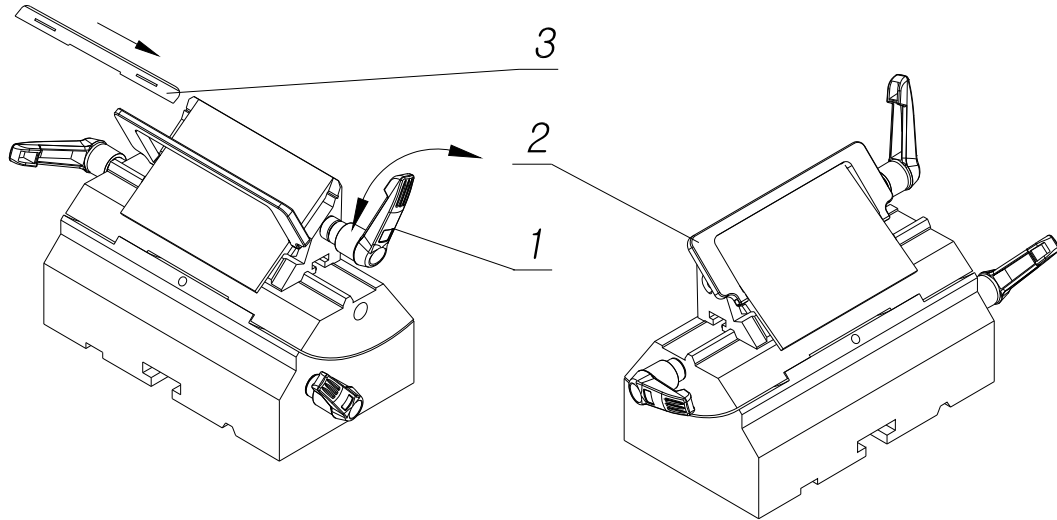

7.3 adjustment of cutting angle

- 1.release tightening handle(1)
2. turn the blade holder, adjust the angle of blade holder according to different specimen hardness and section thickness
- 4.lock the tightening handle , tighten the blade holder on the base of blade holder

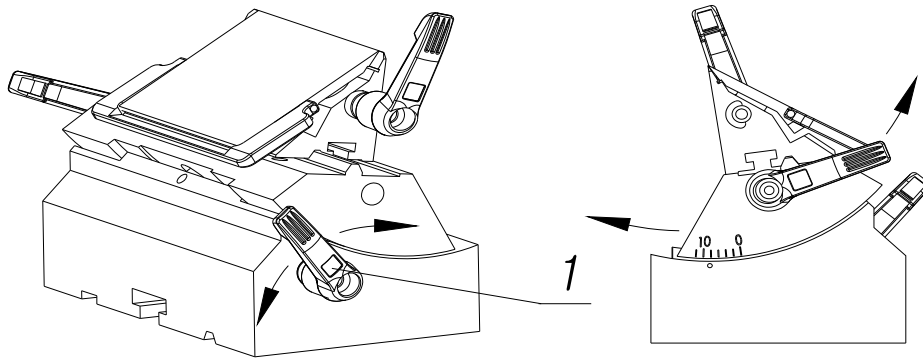

7.4 Sway blade holder

Blade holder(2) can move from side to side,have three anchor point:left,middle,right which take full advantage of blade to rough slice and fine cut effectively, Meanwhile it can save the loss of blade and improve the efficiency of work

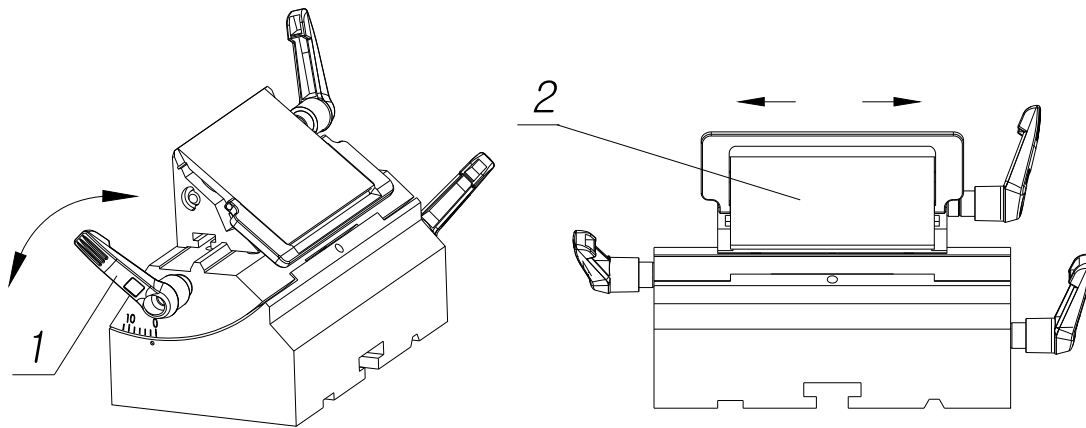

7.5 Safety Precautions of blade holder operating

warn: operating or changing the specimen , knife and disposal blade , even during breaks, it must always cover the cutting edge with the knife guard

1. be careful when adjusting the disposable blade ,because the edge of blade is extreme sharp, inattention may cause injury to your hand

2. don't leave disposable blade and blade holder around,keep unused disposable blade in the knife box always.

3. Blade will never allow to place upward

4. In any case not pick up the falling blade and the blader holder with knife by hand

8. Operating of slice

8.1 Selecting of slice thickness

Choose the thickness by adjustment knob(1)on the top right corner of encloser

1.it can be Located effectively to select each level for slice thickness,

1. Section thickness range : 0.5 — 60 μm

2.Slice thickness adjustment: 0 — 2 μm	increment 0.5 μm
2 — 10 μm	increment 1 μm
10 — 20 μm	increment 2 μm
20 — 60 μm	increment 5 μm

1.Instruction window of slice thickness(2) display the slice thickness by choice

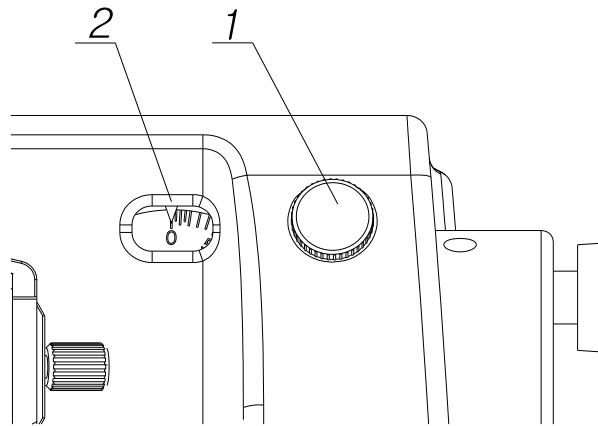

8.2 Fast marching handwheel

1. the specimen can be rapid approach by Fast marching handwheel on the left surface
2. turn the Fast marching handwheel in the direction of arrow, specimen move forward.
3. turn the Fast marching handwheel reverse, specimen move backward.
- 4.the turning will be tough when specimen move to the limit position of stroke ,if turn continue,it will feel slippery to turn the Fast marching handwheel

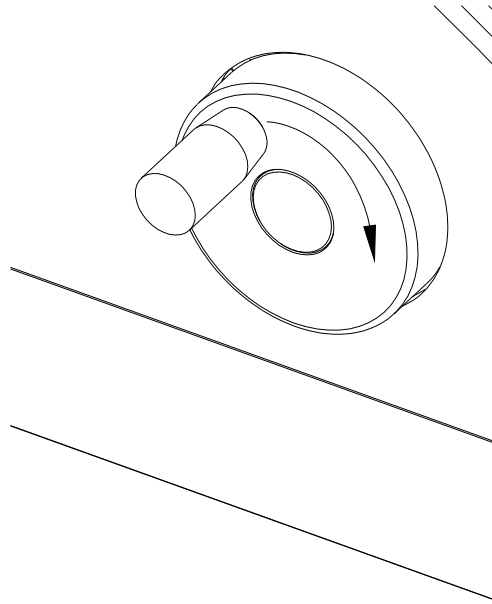

8.3 trimming

1. lock the handwheel safely
2. clamp the specimen
3. clamp disposable blade
4. turn Fast marching handwheel, move specimen in the direction of knife edge or release the spanner of blade holder, move entire subassembly of blade holder, allow knife edge close to specimen
5. check all of gripping holder of specimen clamping device and blade holder, Ensure clamp reliably
6. select a slice thickness (such as 30um) or move small Fast marching handwheel tiny, allow the specimen and knife edge close and touch gradually until trim out a smooth surface of specimen by turning the big Fast marching handwheel,

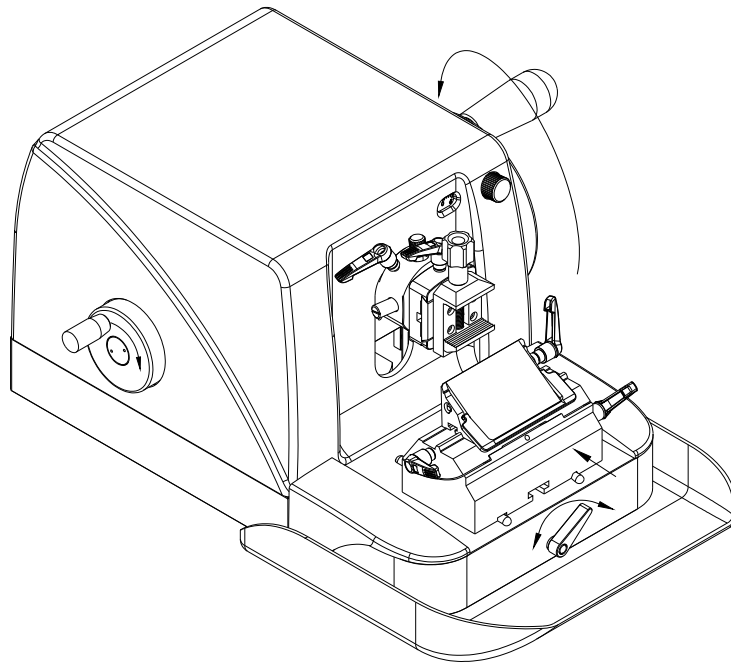

8.4 Slice

select the thickness by adjustment knob on the top right corner of microtome

1. Knife angle should be chosen starting from the smaller angle, increase gradually, until pick out a favorable slice angle
2. turning the handwheel symmetrical and lower the speed to cutting hard specimen when slicing
3. reticle mark on the right of blade holder is been used to select different kinds of slice angle
4. slice specimen by turning the handwheel symmetrical, choose slice to making specimen

8.5 Precautions of paraffin section

Warn. before install specimen or exchange specimen clamp and working clearance, must lock handwheel and cover the device of finger protection .

1. lock handwheel

Warn. prior to clamping specimen then install blade

2. install cool paraffin specimen on the specimen holder

Warn. pay more careful when using the knife or disposable blade, knife edge is sharply,

incorrect manipulation will cause a severe injury.

3. turn Fast marching handwheel, move specimen to back position.
4. insert the blade into blade holder from the side and clamp enough
5. upturn the device of finger protection, cover knife edge
6. adjust the angle of slice, (try it, range 0 to 3)
7. allow the blade holder on the foundation bed close to specimen as far as possible
8. adjust the position of specimen as far as possible parallel with the edge
9. release the handwheel

Warn: turning the handwheel symmetrical when slicing. When slice hard tissue specimen, lower the speed to turning handwheel in order to attaining ideal slice.

10. turn handwheel, start trimming
11. when attain the surface which you want, stop trimming.
12. select the thickness which you want, turn the handwheel clockwise with a uniform speed and slice.

8.6 adjust specimen

Warn. before install specimen or exchange specimen clamp and working clearance, must lock handwheel and cover the device of finger protection .

Lock handwheel

1. upturn the device of finger protection, cover knife edge
2. release specimen clamp and carry down specimen, change a new one

8.7 finish work

1. lock handwheel
2. release sickle clip and take out the blade from blade holder, put blade into knife box.
3. carry down specimen from specimen clamp
4. clean out all of slice waste
5. clearing instrumen

9 Problem and solution

Problems	Possible causes	Corrective action
Non-even of sections: The section thickness varies from one section to another. In extreme cases, sections are skipped meaning that a section is not obtained.	<ul style="list-style-type: none"> -Insufficient knife/blade inclination; consequently the Clearance angle is too small. -Insufficient clamping of specimen and/or knife. -Blunt knife/blade. 	<ul style="list-style-type: none"> -Systematically try several Clearance angle adjustments until the optimum angle is found. -Check if all clamps are locked and screws are tightened on the specimen and knife carrier systems. Retighten the clamps and screws if necessary.] -Use a different part of the cutting edge or use a new knife/blade.
Compressed sections The sections are extremely compressed, wrinkled or jammed together.	<ul style="list-style-type: none"> -Blunt knife/blade. -Specimen too warm. -Clearance angle too big. -Sectioning speed too high. 	<ul style="list-style-type: none"> -Use a different part of the cutting edge or use a new knife/blade. -Cool the specimen on a cold plate. - Clearance angle adjustment; systematically decrease the Clearance angle until the optimum adjustment is obtained. -Rotate the handwheel at a lower speed.
The knife "rings" on the cutting specimen when slicing hard specimens. Sections exhibit scratches and chatter marks.	<ul style="list-style-type: none"> -Sectioning speed too high. -Clearance angle too big. -Insufficient clamping of paraffin forceps or knife 	<ul style="list-style-type: none"> -Rotate the handwheel at a lower speed. -Clearance angle adjustment; systematically decrease the clearance angle until the optimum adjustment is obtained. -Check if all levers are locked and screws are tightened on the specimen and knife carrier

	carrier.	systems. Retighten the clamps and screws if necessary.
No more specimen advance and consequently no section produced.	<ol style="list-style-type: none"> 1. Specimen reached the front feed limit. 2. The coarse feed wheel cannot rotate freely. 	<ol style="list-style-type: none"> 1. Turn the coarse feed wheel in the appropriate direction to move the specimen towards the clearance limit. 2. Remove and obstruction.
Not lighting-up and no display when turn-on the power supply switch.	Fuse is burned	Replace the fuse

10. Cleaning and maintenance

Warn.must lock handwheel before cleaning and maintenance instrument,and unload blade holder and blade.

10.1 Disassembly of blade holder

1. release the set lever of blade holder on the foundation bed,carry down subassembly of blade holder
2. release set lever of blade(1),carry down balde carefully
3. release set lever of blade(2), pull out blade holder lateral direction
4. release set lever of slide carriage (3),unload slide carriage of blade holder

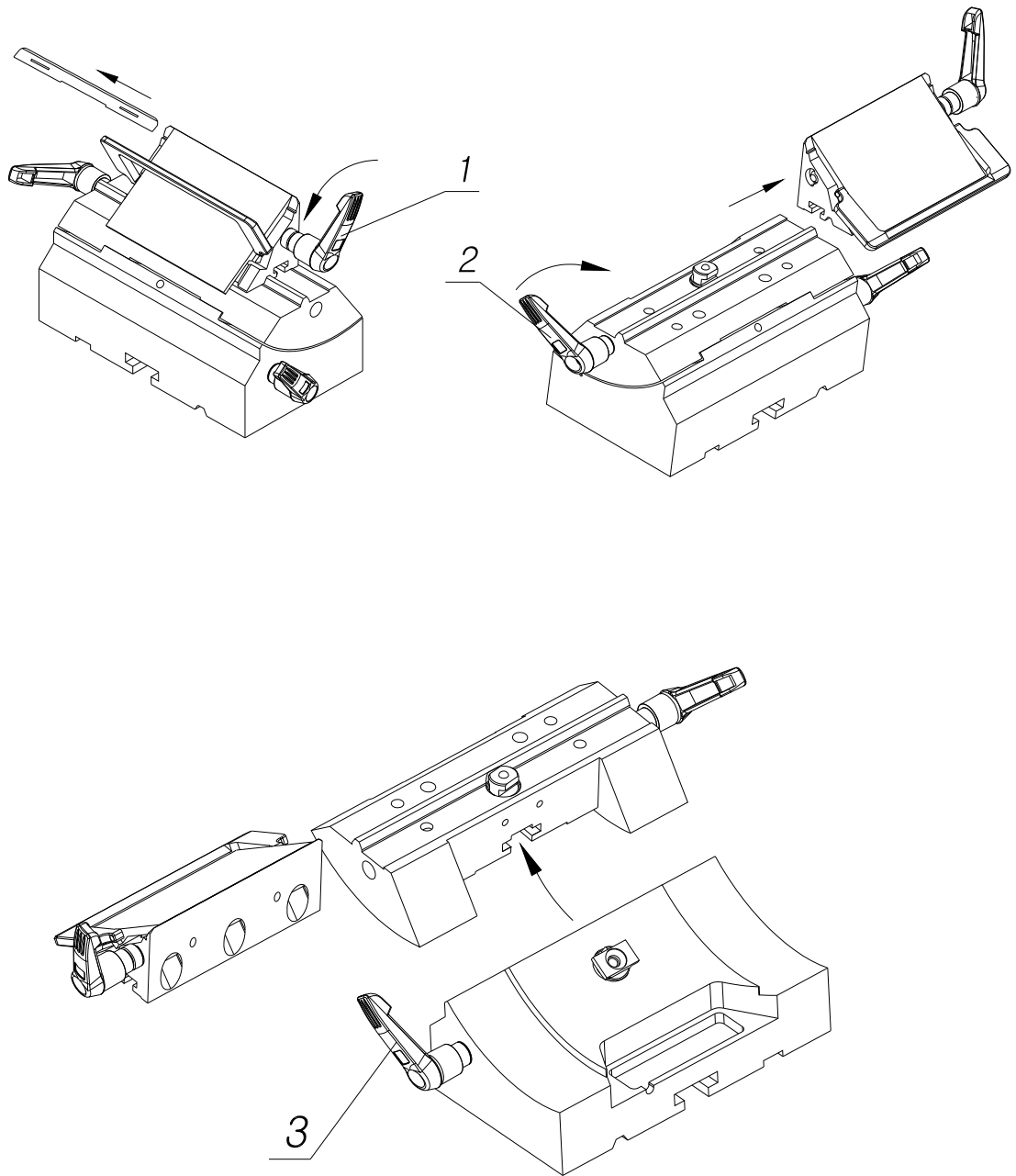

10.2 Cleaning

1. lock handwheel before cleaning the microtome
2. remove slice waste
3. unload waste bath,dump slice waste
4. unload subassembly of blade holder,remove dirty paraffin from clamping part between disposable blade and blade holder carefully.
5. cleaning the instrumen just like Family routine Health, remove dirty paraffin around blade holder carefully.
6. Only use mild commercial detergents or soap solution for cleaning. Do not use

solvent that contains acetone and benzene!

7. Use dry fabric and infected by little detergent to clean the surface of the instrument.
8. make sure, no detergent liquid enter the instrument during the cleaning. After cleaning, dry the surface of the instrument with a soft cloth.
9. Keep cleaning all parts of the instrument after use. Use the blade holder to move on the sliding rail, infuse the detergent lubricant. Good maintenance to the instrument will prolong the life of the instrument.

Warn :allow to use normal commercial detergents or soap solution for disinfection. Do not use solvent that contains gasoline,acetone and benzene!Not allowed liquid to flow inside the instrument

10. cleaning over, install entire subassembly of blade holder and waste bath according Opposite procedure
11. microtome can work long term without daily care, however, in order to operation normally within a long period ,we advice to clean the instrument after end of work. Lubricate the parts of blade holder by lubricating oil that we provide every month. lock Handle shaft、slipper block、pressed compact 、dump rail etc, in order to reach the best result of use.

11.Storage and transportation

1. Environmental temperature: $-5^{\circ}\text{C}\sim+55^{\circ}\text{C}$;
2. Environmental moisture: $\leq 85\%$
3. Atmospheric pressure: 860hpa \sim 1060hpa
4. Before transportation of this machine, please check if it's locked and if marks are complete. the microtome must be erectly transported!

12.packing Isit

Microtome YD-315	1 PC
Lubricating oil	1 bottle
Hexagon spanner	1 pc
Consumers' book	1
Certificate of quality	1

13. Maintenance and after sales service

If any damage, please do not carry out any repairs on your own, as this will invalidate the warranty. Qualified service engineers authorized by our company may only carry out repairs.

If the user operate strictly in accord with this manual, and obey the instruction, we will provide one-year warranty from the date of delivery. Within one year, all damages caused by quality defects, we will be responsible for repairs or replacement free of charge. Besides, we will provide long time maintenance service.

Because of the up to date of technical continuous ,we have the right to make improvement of technical specifications without notification